



## EPZ Railway Carriages Electrical Pre-Heating System

The railway carriages electrical pre-heating system (hereinafter "EPZ") represent an important factor in ensuring travelling comfort not only in winter but – as regards passenger carriages with air conditioning – also in summer, and at the same time, it forms an indispensable form of electricity supplies to laid up railway refrigerator wagons carrying frozen goods.

The EPZ may be divided to two basic types according to the kind of powering the carriages:

- 1) Power supply from the alternating power systems EPZ 3 kV AC 50 Hz, 1,5 kV AC 50 Hz, 1 kV AC 16,7 Hz;
- 2) Power supply from the direct power system EPZ 3 kV DC.

Both types of the EPZ make use the traction power systems as the primary source of electric power. Alternative power system EPZs use the 25 kV AC/TN-C (15 kV AC 16,7 Hz) traction system as their source, while direct power system EPZs apply the 3 kV DC/IT traction system.

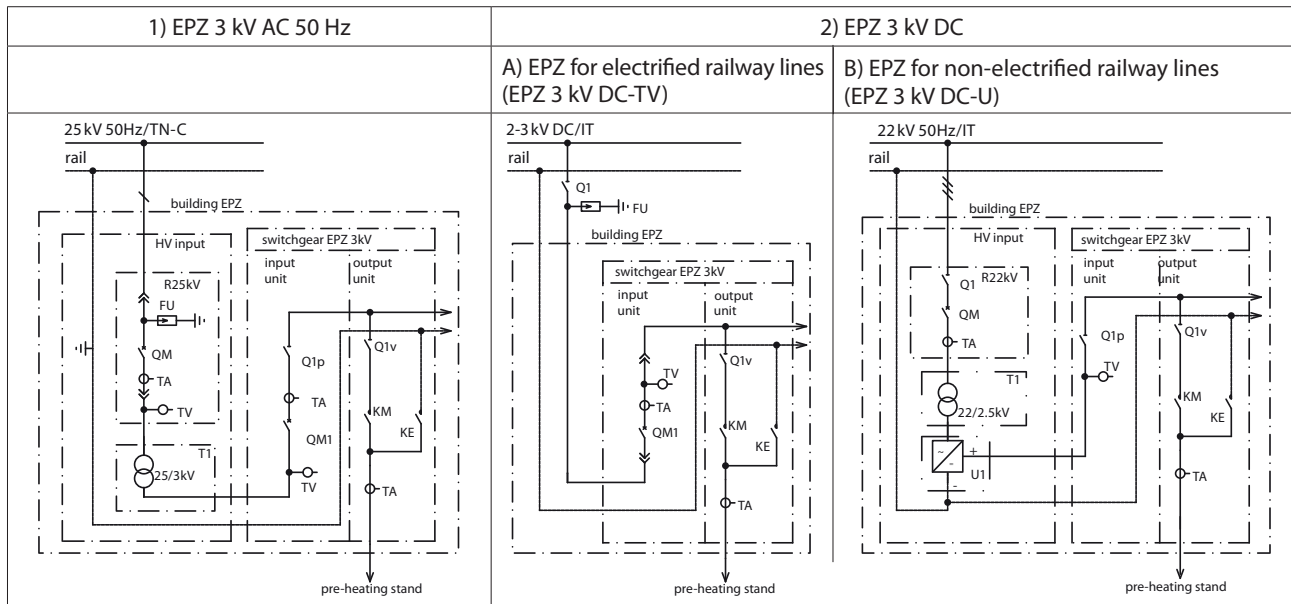

If no traction system is available as a source of power (along non-electrified railway lines), direct power system EPZs may also connect to the 22 kV AC/IT distribution three-phase power system (as well as to another high-voltage 6, 10, 35 kV AC/IT power systems).

### The electrical pre-heating system consists of the following parts

- the high-voltage input part;
- the EPZ 3 kV switchgear consisting of an input unit and output units;
- the pre-heating station (a control box and a pre-heating stand);
- the signaling table in the rolling-stock foreman's or train dispatcher's offices;
- the control system and protection.

### High-voltage input part

The high-voltage input part of the EPZ serves the connection of the electrical pre-heating system to traction, or a distribution system. This part of the EPZ is usually installed in a building. According to the type of the EPZ, the high-voltage input parts differ as follows:

The high-voltage input part of EPZ 3 kV (1,5 kV, 1 kV) AC consists of the 25 kV AC switchgear (for example, the EZB AC II.-NV2 switchgear manufactured by EŽ Praha JSC) and the 25 kV/3 kV transformer.

The high-voltage input part of EPZ 3 kV DC-TV: This type of the EPZ is powered by the 3 kV DC/IT traction system connected directly to the EPZ 3 kV switchgear. There is no high-voltage input part here.

The high-voltage input part of EPZ 3 kV DC-U consists of a 22 kV AC switchgear, a 22 kV/2,5 kV transformer, and a rectifier (the standard versions employ the 6-pulse 3-phase bridge rectifier).

### EPZ 3 kV switchgear

The metal-enclosed EPZ 3 kV switchgear comprises the input unit and several output units. The number of such output units depends on the design applied. The direct-current EPZ 3 kV DC switchgear is designed to comply with the EN 50123-6 ed.2 standard (Railway applications – Fixed installations DC switchgear – Part 6: DC switchgear assemblies) and the alternating-current EPZ switchgear is designed to comply with the EN 62271-200 standard (High-voltage switchgear and controlgear – Part 200: AC metal-enclosed switchgear for rated voltages above 1 kV and up to including 52 kV). The EPZ 3 kV switchgear are usually installed in building.

### The electric equipment in the input units differs according to the EPZ types

- The input units of the EPZ 3 kV (1,5 kV, 1 kV) AC are fitted with a disconnector, a vacuum circuit breaker and voltage and current measuring equipment.
- The input units of the EPZ 3 kV DC-TV are fitted with a high speed circuit breaker placed on a withdrawable chariot (operating as a disconnector), and voltage and current measuring equipment.
- The input units of the EPZ 3 kV-U are fitted with a disconnector and voltage measuring equipment.

The output units are designed so that they can operate with both direct-current and alternating-current EPZs, without

the need of replacing any of the electrical apparatus. The output units can be divided into units with a single supply system or units with a dual supply system (a combination of power supplies, for example, 3 kV AC and 1,5 kV AC). The dual powering system EPZs operate two input units with different voltage systems, which power two independent bus bars extending throughout the entire EPZ switchgear. On the output units, the output voltage can be switched over with help of disconnectors, which are mutually blocked. The electrical equipment of the output units also comprises bus-bar disconnector, a contactor for heating output, a magnetic-driven disconnector serving the grounding of the heating output, an apparatus serving the measuring of current, and if equipment for measuring energy consumption is required, the unit is also fitted with current and voltage sensors.

### Pre-heating station

The pre-heating station consists of the pre-heating stand and the relevant control panel. The heating stand is located next to the tracks (or within the tracks). The heating stand is powered by way of 3 kV DC or AC voltage (and/or 1,5 kV AC, 1 kV AC) cables and then the equipment will be hooked up to carriages or trains with help of a special-purpose high-voltage flexible cable and a high-voltage plug. The heating stand control box is located next to the heating stand and it serves controlling the pre-heating. The control box is made of plastics and it is double insulated.

### Signaling table

This equipment serves the signaling of the state of the electrical pre-heating system. The signaling table is usually placed in the rolling-stock foreman's or the train dispatcher's offices. The state of the relevant apparatus is shown either by signal lamps or upon a display. The signal from the building with EPZ switchgear to the signaling table is carried by way of a metallic cable, either electrically (one conductor/one signal) and or in the form of data transfer (the RS 485, RS 232 lines). Data transfer may also apply to optical cables.

### The control system and protection

The entire EPZ technology is controlled by way of programmable logic controllers (PLC), which facilitates the application of a system of distributed control of all technological parts. The Communication between the individual parts of the EPZ is carried with help of standard protocols (ETHERNET TCP/IP, MODBUS, etc.).

### EPZ 3 kV (1,5 kV, 1 kV) AC

The 25 kV switchgear operates its own programmable controller, which controls the individual elements in the switchgear, communicates with the other EPZ technological parts and with the touch screen. The touch screen allows for the controlling of the individual elements of the power circuit of the 25 kV switchgear as well as the vacuum circuit breaker in the input unit of the EPZ 3 kV switchgear. The touch screen shows all power elements relating to all EPZ technological parts, measuring of voltage and current, and all reports and defects. The 25 kV switchgear operates its own alternate overcurrent protection, which covers the connection between the 25 kV switchgear and the input unit of the EPZ 3 kV switchgear, as well as the transformer.

There is a programmable controller located in each of the units of the EPZ 3 kV switchgear (the input and the output units). The controllers communicate inside the switchgear between themselves and with the other technological parts

of the EPZ. A touch screen is placed in the input unit, which serves the controlling of the power elements in the input unit of the EPZ 3 kV switchgear and the power elements in the 25 kV switchgear. The touch screen shows all power elements relating to all EPZ technological parts, measuring of voltage and current, and all reports and defects. The power elements in the individual output units are controlled via a controlling box located in the track yard. The input units are fitted with alternate current protection preventing an overloading and short circuit on the bus-bar. Each output unit is equipped with AC/DC protection, which prevents overloading and short circuit on the output cable. Overcurrent switching is performed by a vacuum circuit breaker located in the input unit. If there is a request to have an output cable on all three systems of voltage (3kV AC, 1,5kV AC and 1kV AC), there is a possibility to switch between these voltages. For this case there is used switching-over unit, which is part of EPZ 3 kV switchgear and connects given voltages to the main bus bar. EPZ must be equipped with transformer with windings (25kV//3kV, 1,5kV, 1kV).

### EPZ 3 kV DC-TV

A programmable controller is situated in every unit of the EPZ 3 kV switchgear (the input and the output units). The controllers communicate inside the switchgear between themselves and with the other EPZ technological parts. A touch screen is placed in the input unit, which serves the controlling of the power elements in the input unit of the EPZ 3 kV switchgear. The touch screen shows all power elements relating to all EPZ technological parts, measuring of voltage and current, and all reports and defects. The power elements in the individual output units are controlled via a controlling box located in the track yard. The input unit is fitted with a high speed circuit breaker with a short-circuit protection of its own, which covers the main bus-bar in the EPZ 3kV switchgear. Overcurrent load protection of the EPZ 3 kV switchgear is resolved with help of a PLC. Each output unit is equipped with AC/DC protection, which prevents overloading and short circuit on the output cable. Overcurrent switching is performed by a high speed circuit breaker situated in the input unit.

### EPZ 3 kV DC-U

The 22 kV switchgear operates a programmable controller of its own, which controls the individual elements in the switchgear, communicates with the other EPZ technological parts and with the touch screen. The touch screen controls the individual elements of the power circuit of the 22 kV switchgear. The touch screen shows all power elements relating to all EPZ technological parts, measuring of voltage and current, and all reports and defects. The 22 kV switchgear possesses its own alternate overcurrent protection, which covers the connection between the 22 kV switchgear and the input unit of the EPZ 3 kV switchgear, the transformer, the rectifier and also the main bus-bar of the EPZ 3 kV switchgear.

There is a programmable controller located in each of the units of the EPZ 3 kV switchgear (the input and the output units). The controllers communicate inside the switchgear between themselves and with the other EPZ technological parts. In the input unit a touch screen is placed, which serves the controlling of the power elements in the 22 kV switchgear. The touch screen shows all power elements relating to all EPZ technological parts, measuring of voltage and current, and all reports and defects. The power elements in the individual output units are controlled via a controlling box located in the track yard. Each output unit is equipped with AC/DC protection, which prevents overloading and short circuit on the output cable. Overcurrent switching is performed by a vacuum circuit breaker located in the 22 kV switchgear.

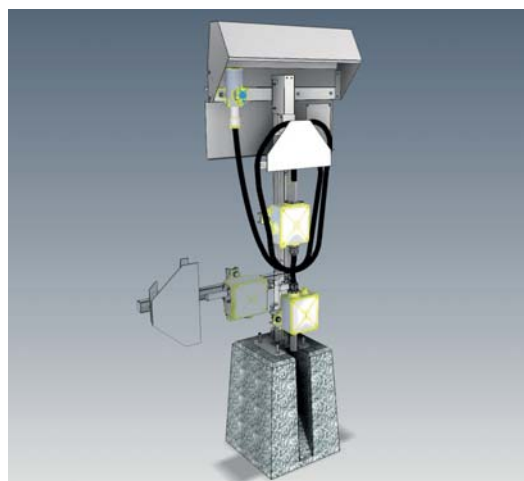

**ELEKTRIZACE ŽELEZNIC PRAHA a. s.**  
 nám. Hrdinů 1693/4a,  
 140 00 Praha 4 Czech Republic

Phone: +420 296 500 101 - Managing Director Secretariate  
 +420 296 500 301 - Commercial Dpt.  
 +420 296 500 311- Export Dpt.  
 e-mail: info@elzel.cz

[www.elzel.cz](http://www.elzel.cz)